

AMOLED

Product Specification

Model Name: AHEM0119-02

Description: 1.19" (390X390) AMOLED

Doc. Version: 04

Customer: Common Customers

Preliminary Specificatio

Final Specification

Prepared	Checked	Approved	Customer's Approval
Yu Zhang			

Contents

Contents	3
1 Scope.....	4
2 Features	4
2.1 Product Applications.....	4
2.2 Product Features	4
3 Mechanical Specifications.....	4
4 Maximum Rating.....	4
5 Electrical Specifications.....	5
5.1 Electrical Characteristics.....	5
5.2 I/O Connection and Block Diagrams.....	8
5.3 Recommended Operating Sequence.....	10
5.4 AC Characteristics (MIPI)	10
6 Electro-Optical Specification.....	13
7 Reliability.....	16
7.1 Environmental Test	16
7.2 Electrical Test.....	16
7.3 Mechanical Test	17
8 Handling Precautions	17
9 Outline Dimension Drawing.....	18
10 packing Specification.....	19

1 Scope

2 Features

2.1 Product Applications

Smart Watch

2.2 Product Features

- 1) Display color: 16.7M (RGB x 8bits)
- 2) Display format: 1.19"(390RGBx390)
- 3) Pixel arrangement: Real RGB arrangement
- 4) Interface: MIPI /SPI

3 Mechanical Specifications

Item	Specification	unit
Dimension outline	33.22 x 34.72 x 0.68	mm
LTPS Glass outline	33.22 x 34.72	mm
Encapsulation Glass outline	Φ33.22	mm
Number of dots	390(W) x RGB x 390(H)	dots
Active area	φ30.42	mm
Diagonal size	1.19	inch
Pixel pitch	78*78	μm
Glass thickness (LTPS/encapsulation glass)	0.2 / 0.2	mm
Weight	TBD	g

4 Maximum Rating

Parameter	Symbol	Spec			Unit	Note
		Min.	Typ.	Max.		
Analog/boost power voltage	VCI	-0.3	-	-	V	-
I/O voltage	VDDIO	-0.3	-	-	V	-
Operating temperature	Top	-20	-	60	°C	-
Storage temperature	Tstg	-30	-	70	°C	-

5 Electrical Specifications

5.1 Electrical Characteristics

5.1.1 Power Characteristic:

Item	Symbol	Min.	Typ.	Max.	Unit	Remark
AMOLED Power positive	ELVDD	4.55	4.6	4.65	V	-
AMOLED power Negative	ELVSS	-2.45	-2.4	-2.35	V	Ref
Digital Power supply	VDDIO	1.65	1.8	1.95	V	Ref
Analog Power supply	VCI	2.7	2.8	2.9	V	Ref

1) Normal Mode

Power Supply: IVDDIO=1.8V VCI=2.8V

Frame Frequency: $F_{frame}=60\text{HZ @ }25\text{degC}$, Brightness 300 nits, Command Mode,

Display Condition	Symbol	Min.	Typ.	Max.	Unit	Remark
100% Pixel On 350nits	IELVDD /ELVSS	-	18.5	22.5	mA	Ref
	IVCI	-	6.0	7.2	mA	Ref
	IVDDIO	-	6.0	7.2	mA	Ref
50% Pixel On 150nits	IELVDD /ELVSS	-	4.5	5.5	mA	Ref
	IVCI	-	6.6	8.0	mA	Ref
	IVDDIO	-	6.0	7.2	mA	Ref
10% Pixel On 50nits	IELVDD /ELVSS	-	0.4	0.5	mA	Ref
	IVCI	-	7.2	8.6	mA	Ref
	IVDDIO	-	6.0	7.2	mA	Ref

2) Idle Mode

Power Supply: IOVCC=1.8V VCI=2.8V

Frame Frequency: $F_{frame}=15\text{HZ @ }25\text{degC}$, Brightness 30 nits,

Display Condition	Symbol	Min.	Typ.	Max.	Unit	Remark
10% Pixel On 30 nits	IELVDD /ELVSS	-	-	-	mA	Supplied by Driver IC
	IVCI	-	3.0	3.6	mA	Ref
	IVDDIO	-	1.0	1.2	mA	Ref

3) Deep Standby Mode

Display Condition	Symbol	Min.	Typ.	Max.	Unit	Remark
Deep Standby	IVCI	-	-	3	uA	-
	IVDDIO	-	-	0.3	uA	-

5.1.2 Power supply circuit application (This is for reference only):

1) RT4723

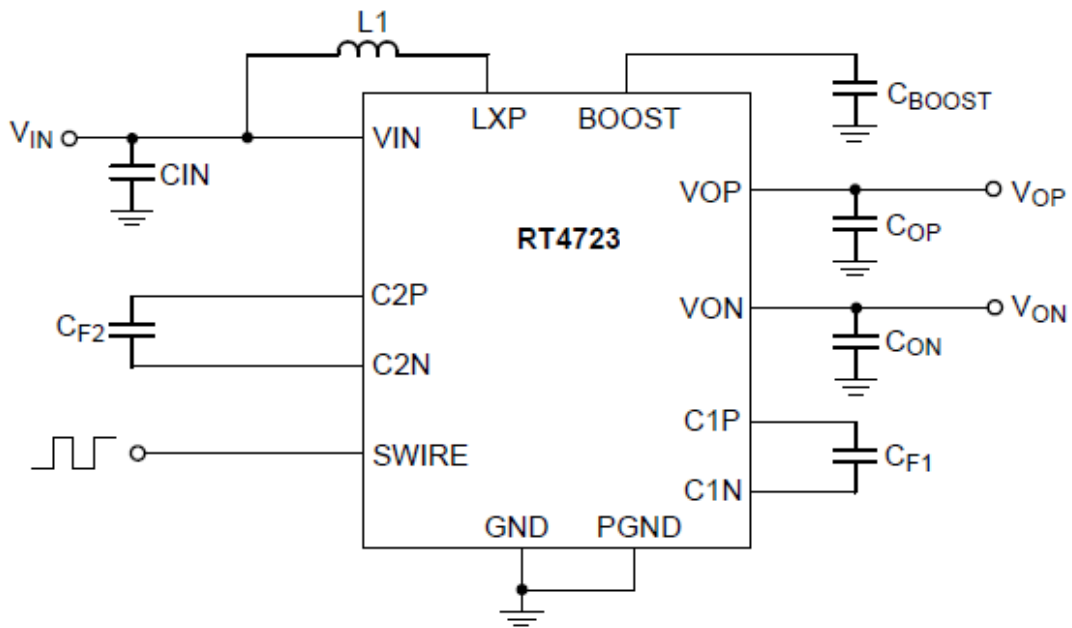

2) SM3321

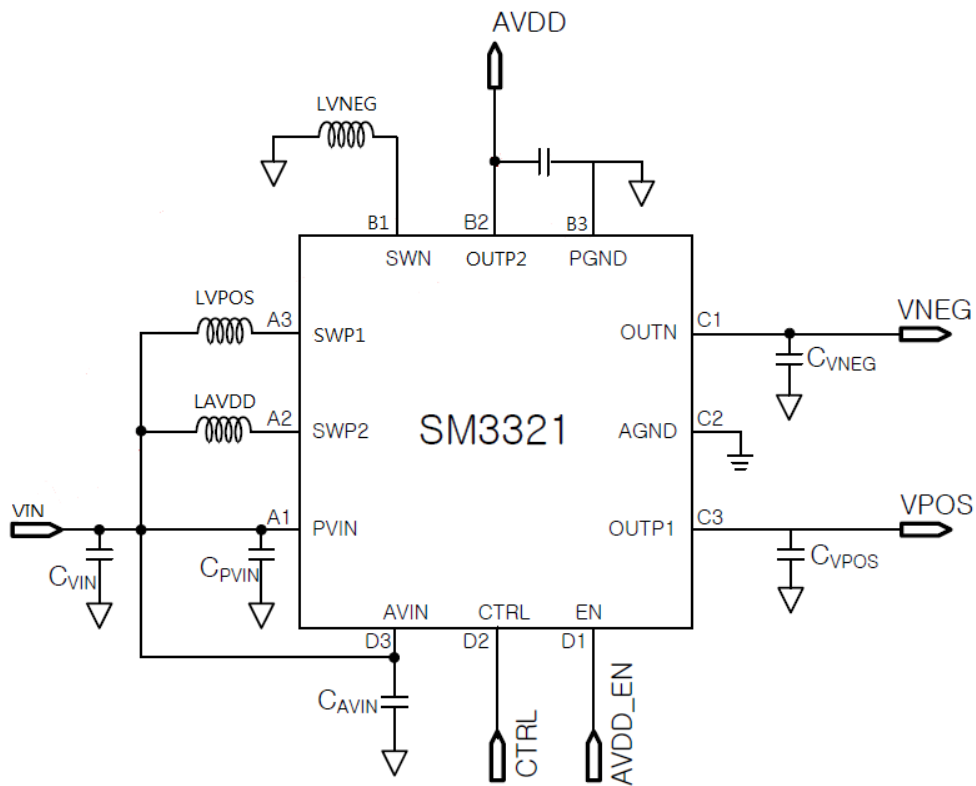

3) TPS65631W

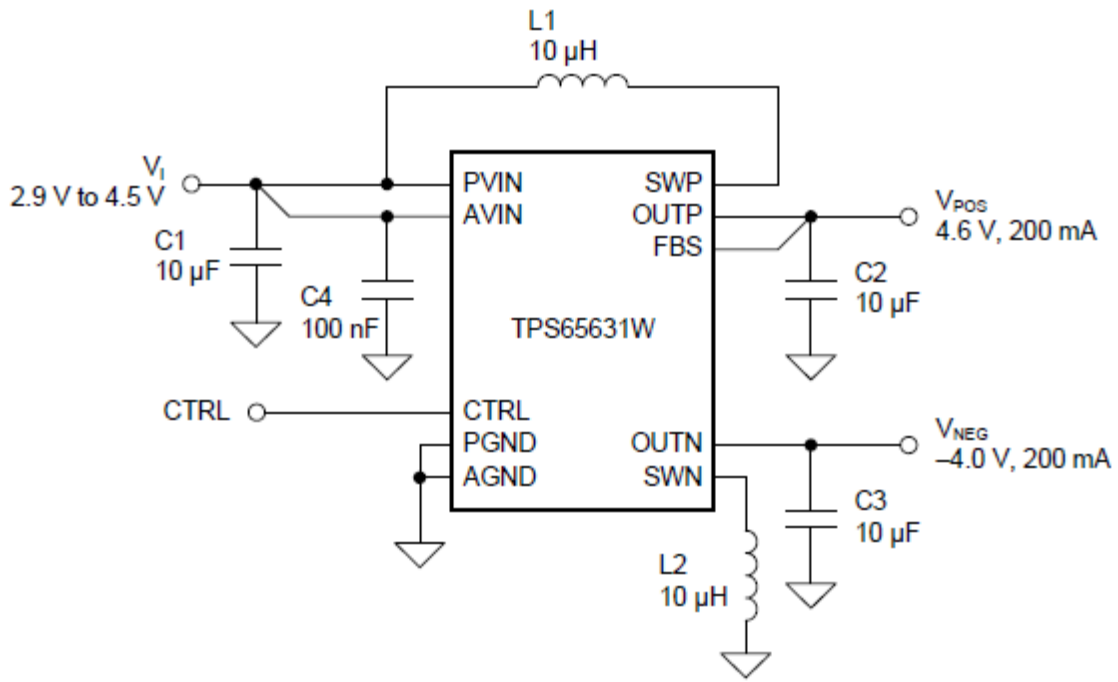

4) STAM1332

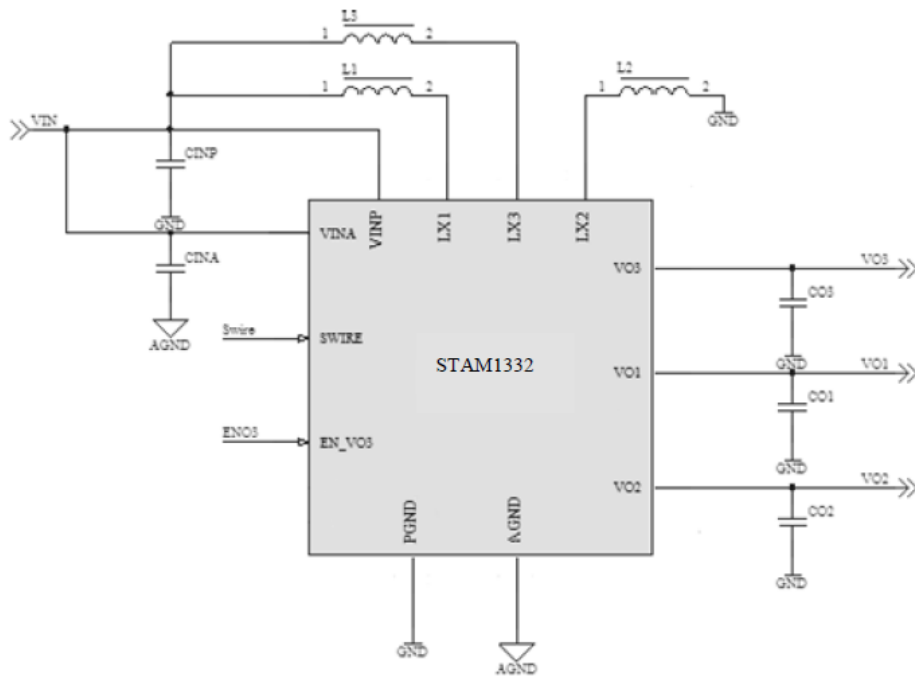

5.2 I/O Connection and Block Diagrams

5.2.1 I/O Connection

#	Pin name	I/O	Description
1	ELVSS	Power	AMOLED power Negative
2	ELVDD	Power	AMOLED power Positive
3	ELVSS	Power	AMOLED power Negative
4	ELVDD	Power	AMOLED power Positive
5	RESX	I	This signal will reset the device and must be applied to properly initialize the chip. Active low.
6	SWIRE	O	Swire protocol setting pin of Power IC
7	VPP	I	Power supply for OTP. Leave the pin to open when not in use.
8	GND	Power	The power ground
9	TE	O	Tear effect output
10	DSI_D0N	I/O	MIPI DSI data0-
11	CSX	I	SPI Enable clock
12	DSI_D0P	I/O	MIPI DSI data0+
13	SCL	I	SPI Serial clock
14	GND	Power	The power ground
15	DCX	I	SPI CMD/Data selection signal
16	DSI_CLKN	I	MIPI DSI clock-
17	SDI	I	SPI Data signal
18	DSI_CLKP	I/O	MIPI DSI clock+
19	SDO	O	SPI Output signal
20	GND	Power	The power ground
21	VCI	Power	Driver IC analog supply
22	VDDIO	Power	Driver IC digital I/O supply
23	VCI	Power	Driver IC analog supply
24	VDDIO	Power	Driver IC digital I/O supply

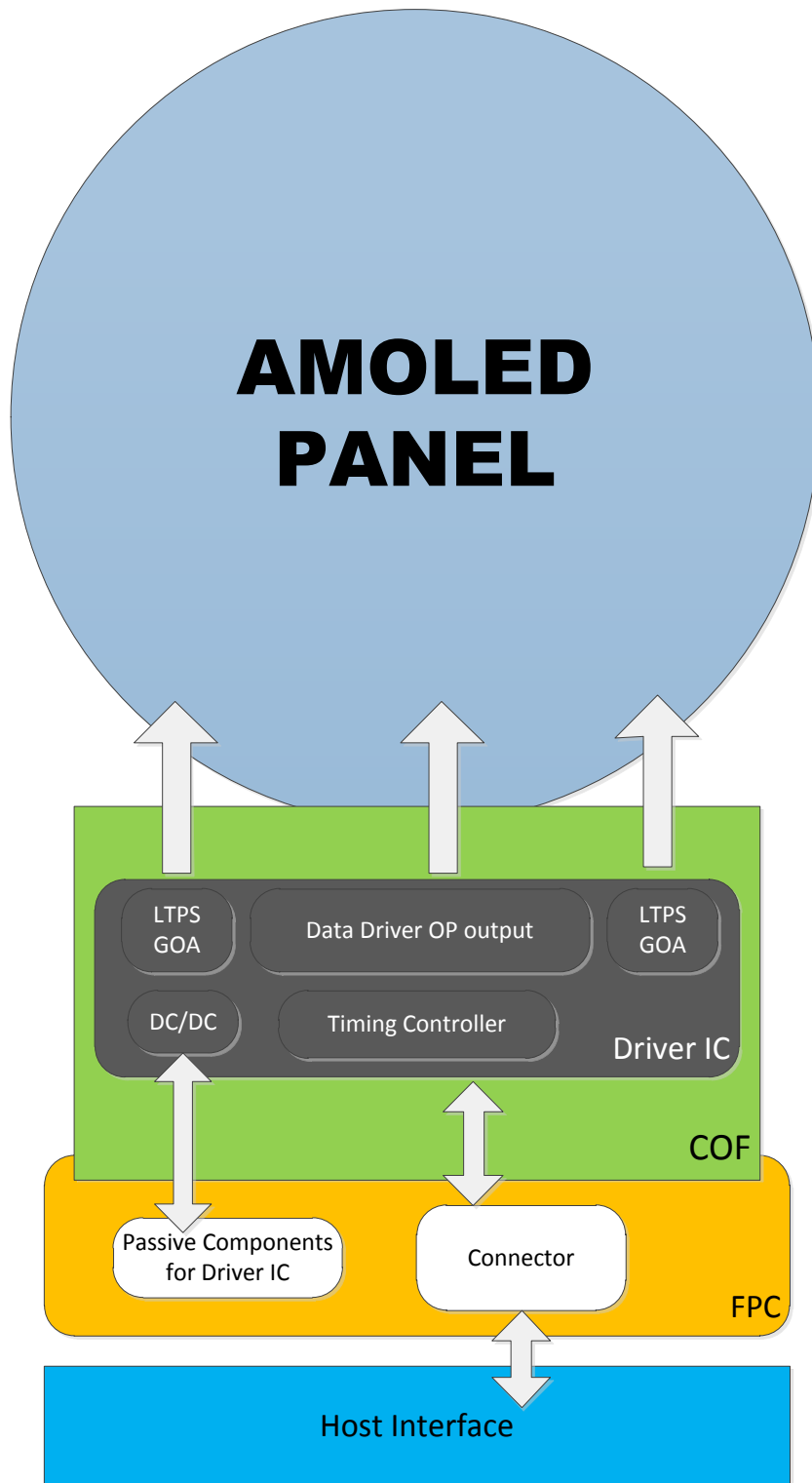

5.4.3 Turnaround Procedure

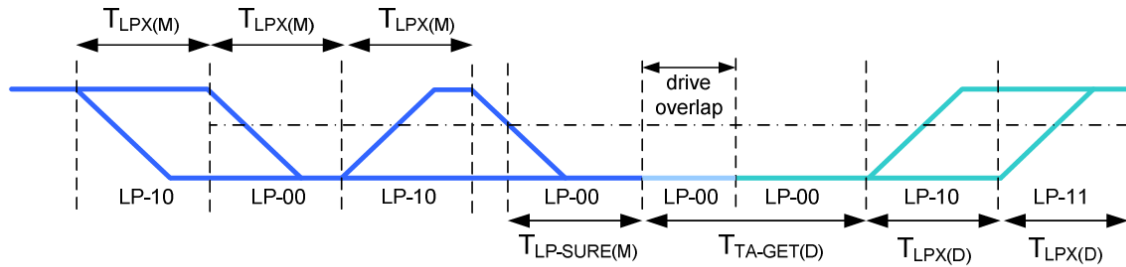

5.4.4 Timing Parameters

Symbol	Description	Min	Typ	Max	Unit
TREOT	30%-85% rise time and fall time	-	-	35	ns
TCLK-MISS	Timeout for receiver to detect absence of Clock transitions and disable the Clock Lane HS-RX.	-	-	60	ns
TCLK-POST*1	Time that the transmitter continues to send HS clock after the last associated Data Lane has transitioned to LP Mode. Interval is defined as the period from the end of THS-TRAIL to the beginning of TCLK-TRAIL.	60ns + 52*UI (For DCS)	-	-	ns
TCLK-PRE	Time that the HS clock shall be driven by the transmitter prior to any associated Data Lane beginning the transition from LP to HS mode.	8	-	-	ns
TCLK-SETTLE	Time interval during which the HS receiver shall ignore any Clock Lane HS transitions, starting from the beginning of TCLK-PRE.	95	-	300	ns
TCLK-TERM-EN	Time for the Clock Lane receiver to enable the HS line termination, starting from the time point when Dn crosses VIL,MAX.	Time for Dn to reach VTERM-EN	-	38	ns
THS-SETTLE	Time interval during which the HS receiver shall ignore any Data Lane HS transitions, starting from	85 ns + 6*UI	-	145 ns + 10*UI	ns

	the beginning of THSPREPARE.				
TEOT	Time from start of THS-TRAIL or TCLK-TRAIL period to start of LP-11 state	-	-	105ns+48*UI	ns
THS-EXIT(1)	time to drive LP-11 after HS burst	100	-	-	ns
THS-PREPARE	Time to drive LP-00 to prepare for HS transmission	40ns + 4*UI	-	85ns+6*UI	ns
THS-PREPARE + THS-ZERO	THS-PREPARE + Time to drive HS-0 before the Sync sequence	145ns + 10*UI	-	-	ns
THS-SKIP	Time-out at RX to ignore transition period of EoT	40	-	55ns+4*UI	ns
THS-TRAIL	Time to drive flipped differential state after last payload data bit of a HS transmission burst	60 + 4*UI	-	-	ns
TLPX	Length of any Low-Power state period	50	-	-	ns
Ratio TLPX	Ratio of TLPX(MASTER)/TLPS(SLAVE) between Master and Slave side	2/3	-	3/2	ns
TTA-GET	Time to drive LP-00 by new TX	5*TLPX	5*TLPX	5*TLPX	ns
TTA-GO	Time to drive LP-00 after Turnaround Request	4*TLPX	4*TLPX	4*TLPX	ns
TTA-SURE	Time-out before new TX side starts driving	TLPX	-	2*TLPX	ns

5.4.5 Timing requirements for RESETB

When RESETB of the reset pin equals to Low, it will be in the condition of reset.

When it is in the condition of reset, it will make the device recover the initial set.

However, in order to avoid the reset noise cause reset, there is a mechanism to judge about whether the reset is needed or not.

The closed interval of Low can be shown as the following.

(Test condition: VDDIO=1.65V~3.6V, VSS=0V, TA=-20°C~+70°C)

Parameter	Symbol	Conditions	Spec			Unit
			Min.	Typ.	Max.	
Reset low pulse width	Trst	-	20	-	-	μs

Table: Reset timing

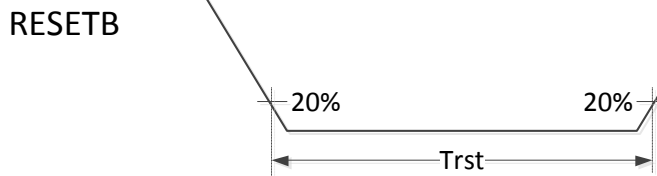

Figure: Reset timing

6 Electro-Optical Specification

Test condition: IOVCC=1.8V , VCI=2.8V , Ta=25°C

Item	Symbol	Condition	Value			Unit	Note	
			Min	Typ	Max			
Luminance		$\theta=0^\circ$	315	350	385	cd/m ²	Note 1	
Uniformity		$\Phi=0^\circ$	80		-	%	Note 2	
Viewing Angle	Left	θ_L	$Cr \geq 200$	80	85	-	Deg.	Note 3
	Right	θ_R		80	85	-		
	Top	ψ_T		80	85	-		
	Bottom	ψ_B		80	85	-		
Contrast Ratio	CR	$\theta=0^\circ$	5000	10000	-	-	Note 4	
Response Time	$Tr+Tf$	$\Phi=0^\circ$	-	2	4	ms	Note 5	
Color Coordinate of CIE1931	Red	X	$\theta=0^\circ$ $\Phi=0^\circ$	0.635	0.665	0.695	-	-
		Y		0.304	0.334	0.364		
	Green	X		0.17	0.22	0.27		
		Y		0.67	0.72	0.77		
	Blue	X		0.10	0.14	0.18		
		Y		0.003	0.04	0.08		
	White	X		0.28	0.30	0.32		
		Y		0.29	0.31	0.33		
NTSC Ratio	NTSC	CIE1931	85	100	-	%	-	
Flicker	-	-	-	-30	-	dB	-	
Gamma	-	-	1.9	2.2	2.5		Note 6	
Crosstalk	ΔCT	-	-	-	1.1		Note 7	

Note 1: Luminance measurement

The test condition is measured on the surface of AMOLED module at 25°C.

- Measurement equipment CS2000 or similar equipment (Field of view:1deg,Distance:50cm)
- Measuring surroundings: Dark room.
- Measuring temperature: Ta=25°C.
- Adjust operating voltage to get optimum contrast at the center of the display.
- Measuring Pattern: Full white

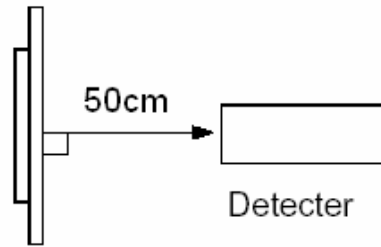

Note 2: Uniformity

The luminance uniformity is calculated by using following formula:

$$\Delta Bp = Bp (\text{Min.}) / Bp (\text{Max.}) \times 100 (\%)$$

Bp (Max.) = Maximum brightness in 5 measured spots

Bp (Min.) = Minimum brightness in 5 measured spots.

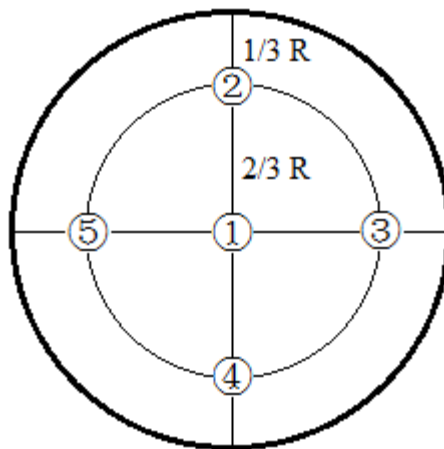

Note 3: The definition of Viewing Angle

Refer to the graph below marked by ϑ and ϕ

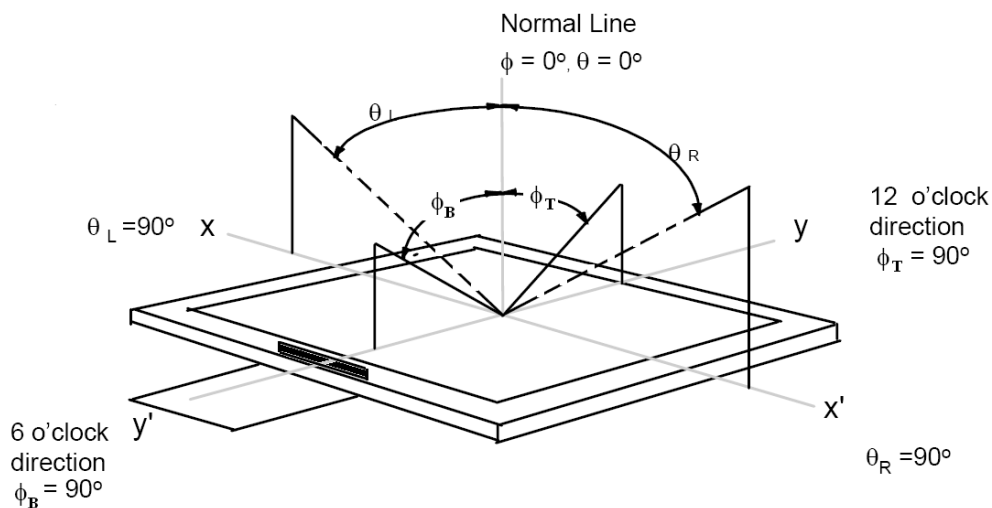

Note 4: The definition of Contrast Ratio:

Luminance When AMOLED is at "White" state

$$\text{Contrast Ratio (CR)} = \frac{\text{Luminance When AMOLED is at "White" state}}{\text{Luminance When AMOLED is at "Black" state}}$$

Note 5: Definition of Response time.

The output signals of photo detector are measured when the input signals are changed from “black” to “white” (Voltage falling time) and from “white” to “black” (Voltage rising time), respectively. The response time is defined as the time interval between the 10% and 90% of amplitudes. Refer to figure as below.

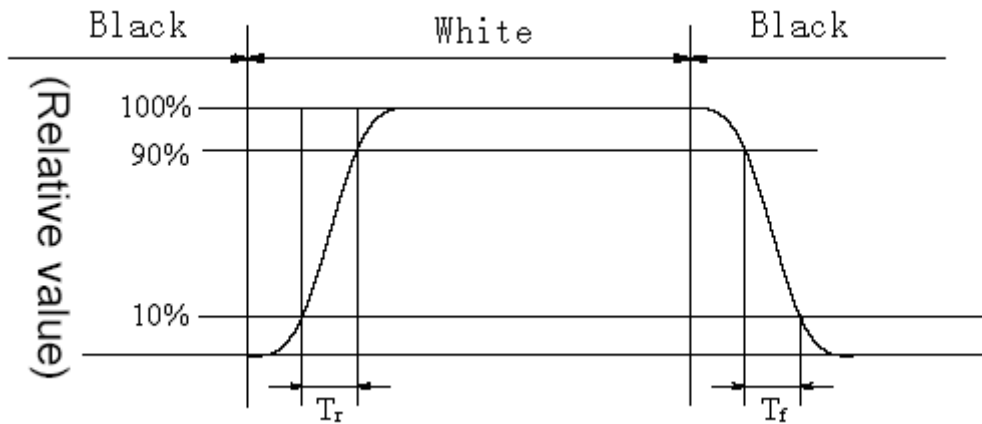

Note 6: Gamma curve

The whole curve’s tolerance must control within +/-0.3, test the gray scale below:
 8, 16, 25, 33, 41, 49, 58, 66, 74, 82, 90, 99, 107, 115, 123, 132, 140, 148, 156, 165, 173, 181, 189, 197, 206, 214, 222, 230, 239,

Note 7: Crosstalk

- There should be no visible cross-talk in normal direction of the display when the two “Cross-talk Test Patterns” below are loaded.
- Measurement equipment: CS2000 or similar equipments
- The point should be marked is, the background of Cross-talk Test Pattern-“gray “ are defined as middle gray scale . For example, RGB 24bit “gray” defined as below:

R7	R6	R5	R4	R3	R2	R1	R0	G7	G6	G5	G4	G3	G2	G1	G0	B7	B6	B5	B4	B3	B2	B1	B0
1	0	0	0	0	0	0	0	1	0	0	0	0	0	0	0	1	0	0	0	0	0	0	0

- $\Delta Bpn = Bpn (\text{gray}) / Bpn (\text{white})$
- Which n means the dot No. In the Cross-talk Test Pattern ;
- Bpn (gray) means the brightness of the No.n spots in Cross-talk Test Pattern;
- Bpn (white) means the brightness of the No.n spots in Full white Test Pattern;
- $\Delta Bp (\text{Max.}) = \text{Maximum value in } \Delta Bp1 \sim \Delta Bp4.$
- $\Delta Bp (\text{Min.}) = \text{Minimum value in } \Delta Bp1 \sim \Delta Bp4.$
- $\Delta CT = \Delta Bp (\text{Max.}) / \Delta Bp (\text{Min.}).$
- ΔCT must be less than 1.10

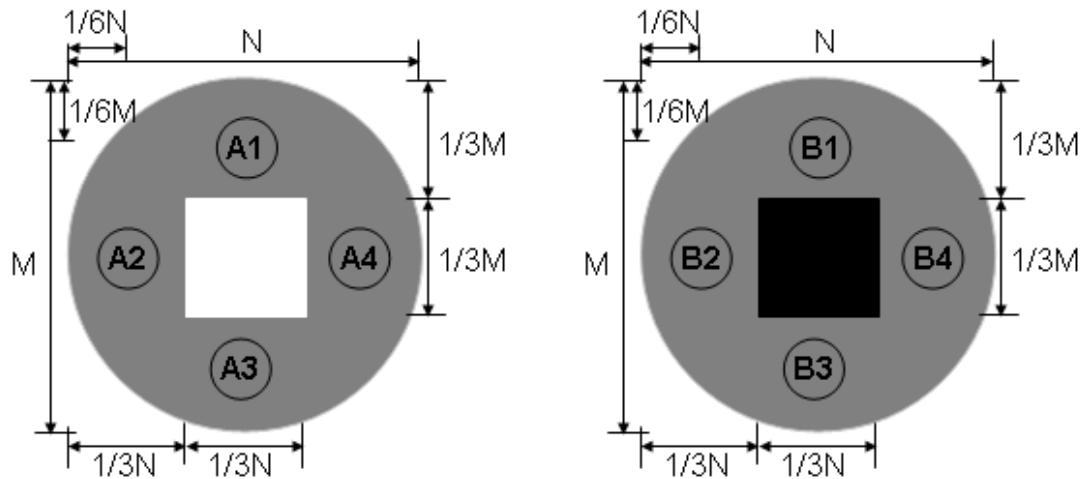

Cross-talk Test Pattern

7 Reliability

7.1 Environmental Test

Item	Main spec	No. of failures / No. of examinations	Note
High Temperature Operation	70°C / 128hours	0/5	
Low Temperature Operation	-20°C / 128hours	0/5	
High Temperature Storage	80°C / 128hours	0/5	
Low Temperature Storage	-30°C / 128hours	0/5	
High Temperature Humidity Operation	60°C/90%RH 128hours	0/5	
Thermal Shock	-40°C~80°C 0.5hr, 30 cycles	0/5	

7.2 Electrical Test

Item	Main spec	Note
Air Discharge	±2kV, 150pF/330Ω (Module level)	5Points, Each 2times. No degradation of OLED performance after this test.
Contact Discharge	±2kV, 150pF/330Ω (Module level)	

7.3 Mechanical Test

Item	Main spec	Note
Drop Test	Drop the packing from 75cm height, 3 times for 6-faces, 3-edges and 1-corner	Package
Vibration-proof test	2g, f=10->55->10Hz apply in each of X, Y, and Z direction for 30 min	Package

8 Handling Precautions

- 8.1 When cleaning ITO pad, avoid using hard and abrasive material or corrosive solution
- 8.2 Keep module away from direct sunlight or fluorescent light, and keep it at room temperature and humidity
- 8.3 Strong impact & pressure on module and packing is prohibited
- 8.4 Following normal power on/off sequence is necessary for preventing abnormal display or permanent damage to display
- 8.5 Optimal contrast ratio under ideal voltage is AMOLED module's characteristic, hence it is recommended a voltage control function available
- 8.6 Image sticking may occur if an image displays for an extended period of time
- 8.7 When interfered by system's overall mechanical design, an abnormal display may occur
- 8.8 After considering emitting energy, you should plan your design to satisfy EMI standards.
- 8.9 Host side should place a surge-prevent circuit at power trace (ie: VCI, Vddi) to protect AMOLED module.

9 Outline Dimension Drawing

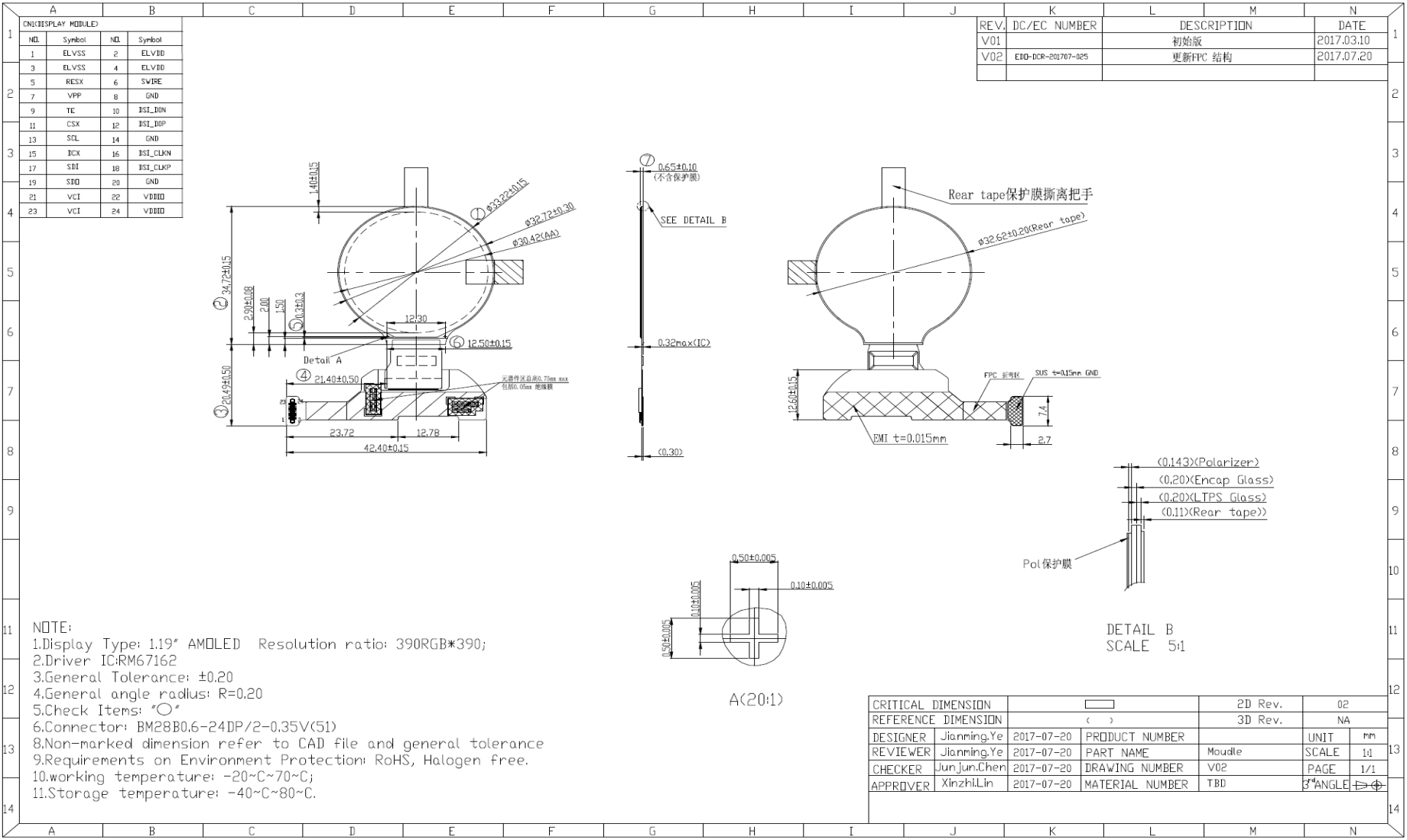

10 packing Specification

1. 整箱材料说明						
NO	料号	品名	材料	尺寸 (mm)	数量 (个)	备注
1	TBD	AEM0119-02	FOG	34.72*32.22	288	
2	16.13001.010/020	外箱标签	纸	52*100*0.1	1	
3	16.13002.010/020	内箱标签	纸	52*100*0.075	2	
4	21.13155.010/020	吸塑盘	PET	455*290*14	20	
5	21.13156.010/020	EPE-Spacer	EPE	374.03*232.5*1	36	
6	21.13011.010/020	EPE填充物 (规格2)	EPE	395.24*220.46*1	4	
7	21.13003.010/020/30	纸箱	纸	516*338*248	1	
8	21.13004.010/020/30	纸盒	纸	459*294*115	2	
9	21.13005.010/020	干燥剂	干燥剂	55*75	4	
10	21.13006.010/020/30	静电防尘袋	PE	660*440*0.28	2	
11	21.13010.010/020/30	PP板	PP	457*292*5	2	
12	21.13012.010/020/30	EPE护角	EPE	120*244*100	4	
13	TBD	栈板	木材	TBD	1/30	

2. 整栈板产品数量说明	
(1) 整个吸塑盘的产品数量	每列的产品数量4个X每行的产品数量4个=16个
(2) 整个纸盒的产品数量	整个吸塑盘的产品数量16个X包装产品的吸塑盘数量9个 (不包括最上方的空盘) =144 个
(3) 整个纸箱的产品数量	整个纸盒的产品数量36个X包装产品的纸盒数量2个=288个
(3) 整个栈板的产品数量	整箱产品数量288个X纸箱的数量30个=8640个

